

## CAUTIONS:

1. For DC and DCL models, battery and solar panel VOLTAGE POLARITIES MUST BE CORRECT before applying power.
2. Do not allow battery voltage for DC models to fall below 12.0 volts DC or be above 15.0 volts DC.
3. Do not exceed the electrical ratings specified.
4. Keep door locked and holes plugged. Damage due to exposure to environment voids warranty.
5. Use a second pair of pliers or wrench to hold post on PD when tightening fittings.
6. Do not power 115 VAC transformers with 230 VAC. 230 VAC transformer is marked "230".

## ELECTRICAL INFORMATION

Recommended Input Voltage: 110-130 VAC for 115 VAC Controller. 210-240 VAC for 230 VAC Controller (Single Phase)  
DC/DCL 12.0 to 14.0 VDC

Idle input current draw:AC/DC: .03 Amp at 115 VAC or 12 VDC

DCL: .03 Amps at 12 VDC

Output ratings: AC or DC: 1.6 Amps AC or DC, 50 or 60 Hz

If a fully charged car size battery is used with 80 amps-hour capacity without a solar panel, about four months of service can be expected before recharging when using latching solenoids with the DCL model.

A 7 amp-hour rechargeable battery with 5 watt solar panel should operate the DCL models continuously as long as there are no more than 5 consecutive sunless days.

## LIMITED WARRANTY AND LIABILITY AGREEMENT

Upon purchase, users of all Alex-Tronix products agree to the following terms, conditions, and limitations of warranty and liability coverage:

Alex-Tronix warrants its products to be free from original defects for one year from the date of original sale. The manufacturer will replace, free of charge, any part found defective under normal use and service within the guarantee period, provided the product is installed, used, and maintained in accordance with any applicable instructions or limitations issued by Alex-Tronix. Components supplied as replacement parts are warranted for 90 days from the date of shipment. The manufacturer assumes no liability for incidental or consequential damage sustained in the adoption or use of our engineering data, service, or products. Liability is therefore limited to the repair of the products manufactured by Alex-Tronix. No agent or representative of Alex-Tronix has the authority to waive or add to this agreement. Altered products or use of products in a manner not intended shall void this warranty.

For warranty repair, send defective product freight pre-paid to:

### ALEX-TRONIX A DIVISION OF GNA INDUSTRIES, INC.

4761 West Jacquelyn Avenue • Fresno, California 93722

Telephone (559) 276-2888 • FAX (559) 276-2890 • Toll Free (888) 224-7630

E-Mail: controls@alex-tronix.com • <http://www.alex-tronix.com>



**FILTER BACKWASH CONTROLLERS**

**MODELS NF4/F8 AC/DC/DCL-D**

# OWNER'S MANUAL

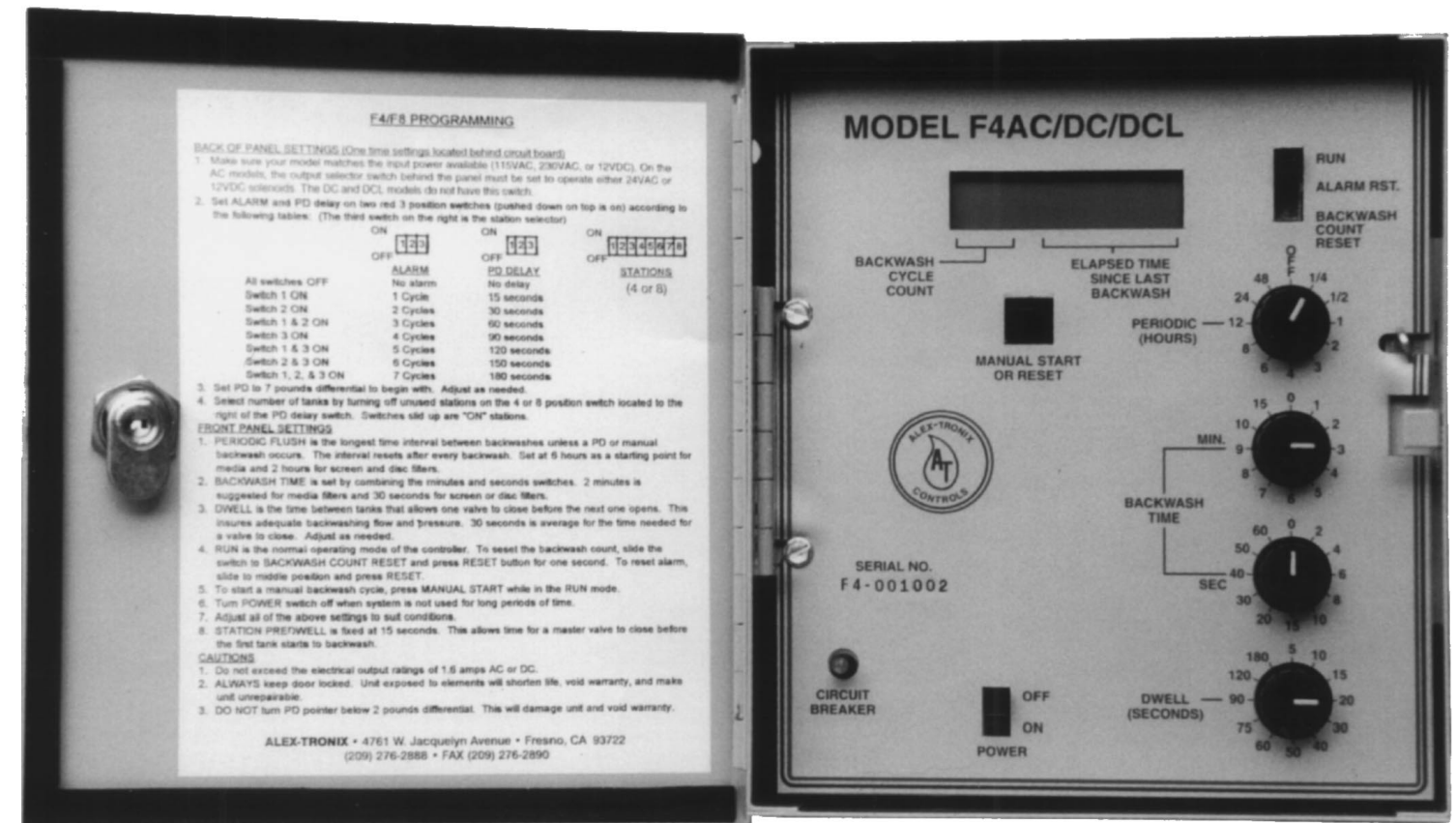

Alex-Tronix backwash controllers will operate any filter with any common input voltage and 24 VAC, 12 VDC, and 12 VDC latching solenoids.

## INSTALLATION:

Mounting controller to wood panel or post by means of wood screws provided or to bracket on filter manifold. Use 1/2 inch conduit to house electric wiring. For 115 VAC model, use 14 or 16 gauge wire to 115 VAC leads of the transformer in the case. The three transformer secondary (24 VAC, center tapped) leads are already attached to the output terminal strip.

**CAUTION:** Standard controller has 115 VAC transformer. For 230 VAC input, replace 115 VAC transformer with optional 230 VAC transformer. Powering 115 VAC transformer with 230 VAC will damage transformer and void warranty. 230 VAC transformers are marked 230 VAC.

The terminal is shown below:

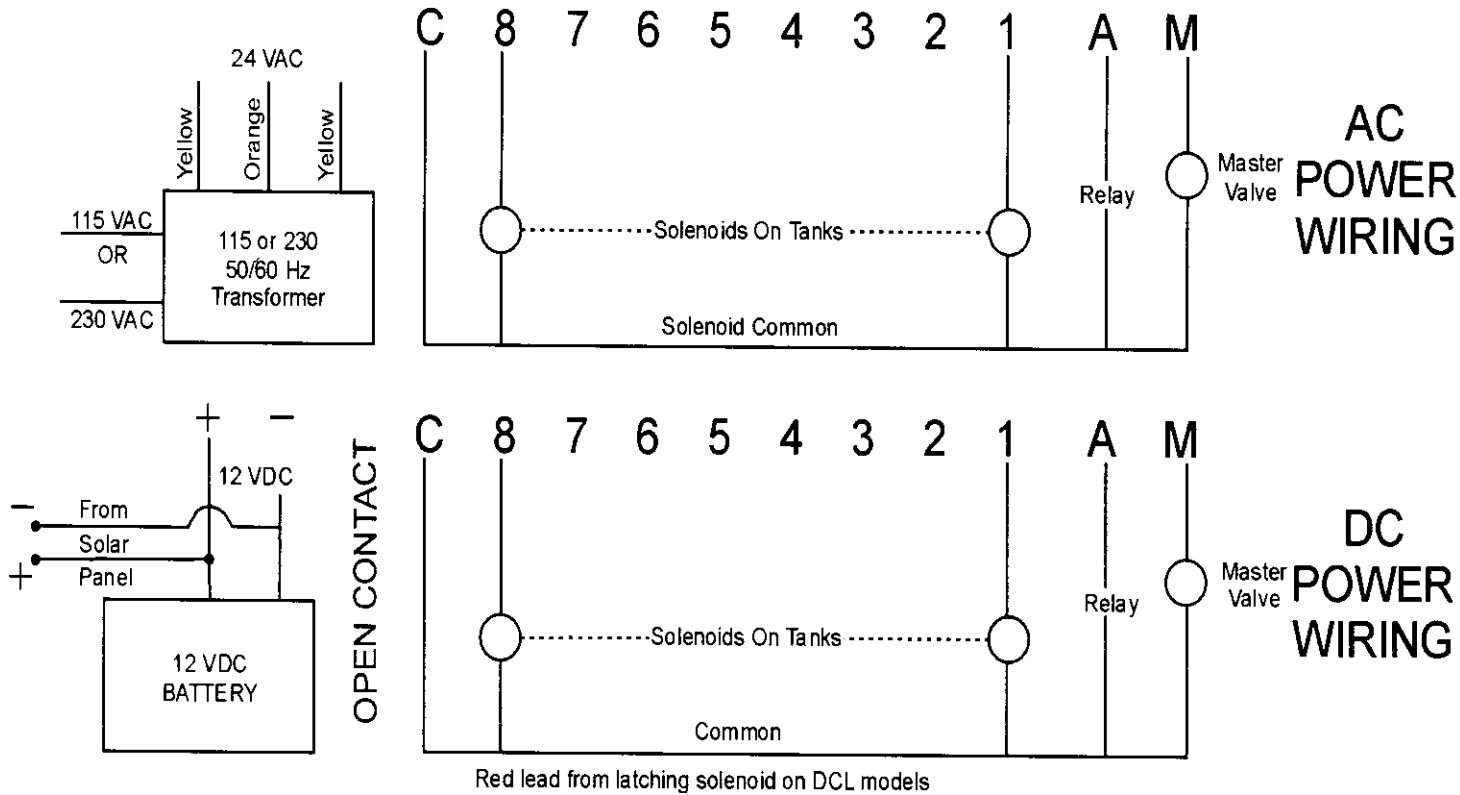

- 24 VAC OR 12 VDC: Input power of 12 VDC from battery and solar panel or 24 VAC from center tap transformer.
- C: Common to all solenoids - 24 VAC, 12 VDC, or 12 VDC latching (Use positive or red lead). This common is also attached to alarm relay (not supplied).
  - M: Master valve becomes energized as soon as the cycle starts. After the pre-dwell time, the first programmed station is activated. Master valve goes off when the last station shuts off. This output is used in case of marginal pressure conditions whereby closing a field or a master valve allows pressure to be maintained to effectively flush out the screen, media, or disc filter.
  - A: Alarm output to indicate excessive backwashing. Attach to a relay to turn on light or bell.
  - 1-8: Output terminal to each station solenoid "hot" lead.
- Note: Pressure differential input is on a separate two pin plug in connector.

For the DC and DCL models, it is VERY IMPORTANT TO OBSERVE THE POLARITY OF THE 12 VDC CONNECTIONS. DO NOT USE 24 VDC.

For the DCL where solar panel is used, observe proper polarity when connecting the solar panel leads to the DC terminals. If the diesel generator battery is used, observe polarity and voltage and connect the correct + and - terminals. Make sure the batteries are not 24 VDC. The recommended operating voltage is 12.0 to 15 volts D.C. For optimum battery life, use a 7 amp - hour or greater rechargeable battery for DCL operation.

Use two wire latching solenoids with DCL models by connecting the positive (red lead) to the common terminal "C". The black lead from each solenoid is attached to the 1-8 terminals. Reversing these leads will not damage the controller but the solenoid will not operate properly.

## PROGRAMMING:

Referring to the front panel controls, first turn on POWER. Set the PERIODIC FLUSH to desired backwash interval. Note: Periodic interval resets after each backwash. For example if the periodic is set for once an hour and the PD starts a cycle 53 minutes later, the periodic will not start a cycle 7 minutes later, but reset for an hour later.

For screen or disc filters, once every 2 hours may be a good starting point. For media filters, once every six hours. Set BACKWASH TIME to 30 seconds for screen, 2 minutes for media. Set DWELL time for 15 seconds for screens and 30 seconds for media. Depending on water quality, type of filter, and valve operating time, change these settings to suit. The minutes and seconds settings can be added to provide a wide range of backwash time selections.

Now swing open the front panel and find the 4 or 8 position DIP switch on the back on the circuit board. Select the number of tanks that are to be used. Sliding the small switches up (on) allows the stations selected to become energized. You need not necessarily use the first six stations, for example. Any combination may be used.

Now locate the 3 position PD delay mini-switch on the back of the board also shown on lid instructions. Set switches 1, 2, & 3 according to the chart. For example sliding switches 1 and 3 on gives a PD delay of 120 seconds.

The three position dip switch located to the left of the PD delay switch is the pre-dwell delay, which is adjustable from 0 to 105 seconds. Consult the door lid sticker for switch settings. Pre-dwell time insures the first tank has just as much backwash time as the other tanks, particularly when a field valve needs to be closed prior to a backwash cycle. The display says PREDWELL during this time.

To select latching output, slide single DIP switch to LATCH while display shows IDLE. A small "L" in the display next to the backwash count shows output is latching.

### The ALARM works as follows:

ALARM will automatically flash intermittently on the display if three or more consecutive backwashes have occurred initiated by a signal by the pressure differential gauge. This indicates that the filter is either not cleaning well enough to reduce the pressure differential, or that the gauge itself may be defective or improperly set. During the alarm indication, the controller continues to function normally. A relay may be used at the output terminal "A" position to activate an external light or bell.

Now set the PD gauge to the desired setting. Most settings are in the 6 to 8 pounds differential range. Some industrial applications may require higher settings. Now connect tubing from the manifold to HI and LO ports of PD gauge. The HI port is in the center of the gauge. Fittings will be required. After making sure that all wiring is secure and proper, close front panel.

Returning to the front panel, PD is displayed when the pressure differential exceeds set point. After the programmed PD delay, the controller will initiate a backwash cycle as long as the PD has been continuously energized during that period, indicating a truly dirty filter.

The display shows which tank is backwashing or in dwell. The DWELL TIME allows one valve to close before the next one opens in order that maximum pressure is maintained for best cleaning on the screen, media, or disc.

The MANUAL START button allows a manual start of a backwash cycle. To start, the slide switch must be in RUN. Press the MANUAL START button for about 1 second. To advance to the next programmed station, release for a second, then push again. Once the cycle has been started, it will automatically advance through all programmed stations.

## DISPLAY INFORMATION:

1. When the unit is filtering, display shows IDLE.
2. When the PD is activated but not yet in backwash, display shows IDLE WITH PD.
3. Depending upon the predwell setting, the top line will show PREDWELL upon starting a backwash cycle prior to going to the first tank.
4. On the second line, a backwash cycle count is displayed with is resetable by sliding front panel switch to BACKWASH COUNT RESET and pressing RESET button for one second.
5. The second line also indicates the elapsed time since the last backwash cycle.
6. In latching mode used with the solar panel, a small "L" shows up next to the backwash count.
7. During power failure, backwash cycle count is maintained. If power fails during a backwash cycle, unit will resume on that same station when power returns. The elapsed time is frozen during the power failure.
8. After three consecutive PD initiated backwash cycles, ALARM will flash on the display which is reset by sliding front panel switch to ALARM RESET and pressing the reset button for one second.