

Alex-Tronix Service Bulletin No. 18, Rev 0, as of 03-24-2008

Controllers: All 120/240VAC Filter Controllers.

Issue: UL and NEMA Safety Listing.

Electrical safety information for Specifiers, Installers and Electrical Inspectors.

Fellow installers and electrical inspectors:

Once in awhile, I get the question of whether our controllers are UL listed or NEMA rated. Some areas or jobs within the country may require one, or both of these specifications. At this time, due to prohibitive production costs, Alex-Tronix does not provide a controller which is NEMA rated or UL listed. To provide a controller with these features in some cases, would force us to manufacture a controller more costly than the filter itself. Having said this, one should note that we have sold thousands upon thousands of filter controllers for over 25 years *with not a single safety incident* reported to us. If installed properly, our controllers are very safe.

For jobs that require UL listed equipment, the following procedures should be followed -- by qualified electricians only:

1) After mounting controller, jot down the 3 (YEL-ORN-YEL) wire colors and what terminal position they are in, then completely remove the internal transformer and discard; re-fasten the green ground wire back on to the same stud. Please note that you may also order a controller *without* an internal transformer.

2) Purchase a "Boost-Buck" general purpose isolation transformer, and about three feet of 1" flex-conduit/w fittings. We recommend using one of the three transformers listed below:

EGS/SOLA	part# HS19B50
SQUARE D	part# 50SV43A
EATON-HAMER	part# S10N04A81N

These transformers are 50VA, 120/240 VAC input, UL Listed, and will be wired for an isolated 24VAC --with center tapped secondary. These transformers are encased in a small NEMA 3R rated enclosure. See wiring diagram below.

You will need to mount the transformer next to the controller, and install the conduit between the controller and external transformer. Now run three secondary wires from the transformer to the controller. We recommend you color code the secondary wires as follows:

X1=YELLOW (One leg)
X2,X3 = ORANGE (Center Tap)
X4=YELLOW (Remaining leg)



Typical External Transformer Wiring Diagrams

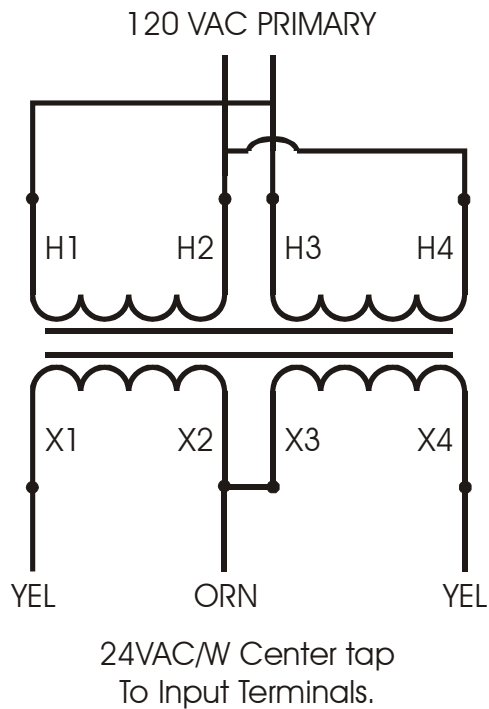
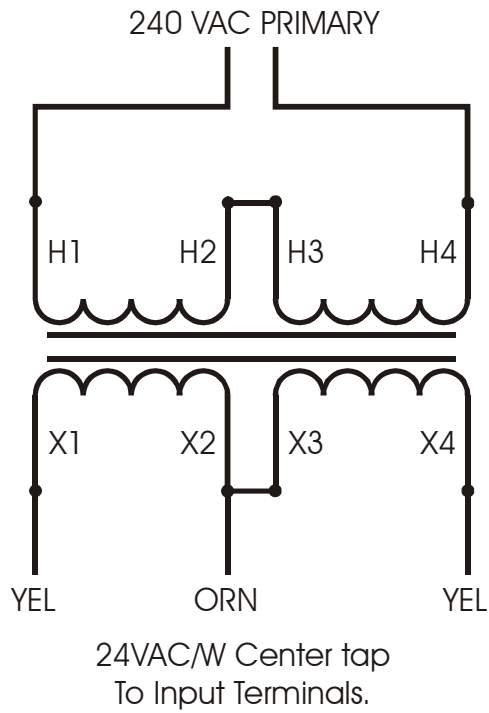

A Special Note To Electrical Inspectors -- Note that our filter controllers are considered “Irrigation Controls” by Underwriters Laboratories, and irrigation controllers are reviewed under the UL document “ELECTRIC PLUMBING ACCESSORIES - UL 1951” (Copyrighted by UL). Though our controllers are not UL listed, once the external transformer is installed, the secondary voltage fed to our controller is considered (by UL) a “LOW-VOLTAGE CIRCUIT” and is designated under the UL compliance rule stated in the document:

Section:

2.4 LOW-VOLTAGE CIRCUIT - A circuit involving a peak open-circuit potential of not more than 42.4 volts supplied by a battery, by a Class 2 transformer, or by a combination of a transformer and a fixed impedance that as a unit, complies with all performance requirements for a Class 2 transformer. A circuit derived from a line-voltage circuit by connecting a resistance in series with the supply circuit as a means of limiting the voltage and current is not a low-voltage circuit.”

“2.4 revised January 14, 2000”

Also:

“23.1.1 All secondary circuits shall be judged under the requirements for primary circuits unless they comply with 23.1.2.

23.1.2 Components, wiring, printed wiring assemblies, insulating material, and so forth, and associated circuitry that are employed in Class 2 circuits as described in the definition of low-voltage circuits or that complies with 23.1.4 and 23.1.5 **need not be investigated** provided that the Class 2 circuit does not perform a safety related function, that is, it is not a safety circuit.”

If our controllers are electrically configured in the said fashion stated above --based on UL-1951, it is reasonable to conclude that our controllers need not require a UL listing, and therefore **should be checked off as a safe installation by local electrical inspectors**. Inspectors with any further issues should contact our company directly and not through the installer.

NEMA RATINGS

Any job that requires a NEMA rated enclosure box must have the pressure differential gauge detached from the controller, and its chassis mounted in a NEMA rated enclosure. The actual rating “2R”, “3R”, etc. may be selected as the job requires.

Since the PD gauge has plumbing with pressurized liquid in the lines, the gauge must be mounted outside of the enclosure to meet NEC compliance. It is not necessary to re-fasten the PD gauge to the outside of the enclosure; locating the PD gauge on other parts of the filter system may be used for convenience.

For F3’s F4’s, and F8’s we recommend Hubbell-Wigman’s part # RSC101006. This is a 10” x 10” x 6” NEMA 2R enclosure. It will allow you to easily access the controller, and can accept a pad lock. For F2’s or F12’s, contact your local electrical supplier to purchase the desired size.

Questions??? Tech Support: Aram Tokatian 888-224-7630 or 559-276-2888 ext. 16.

